

## DIMENSIONS AND SPECIFICATIONS

### Aspen Cased Upflow/Downflow Coils

Designed for Heil N8MP and N9MP Furnaces

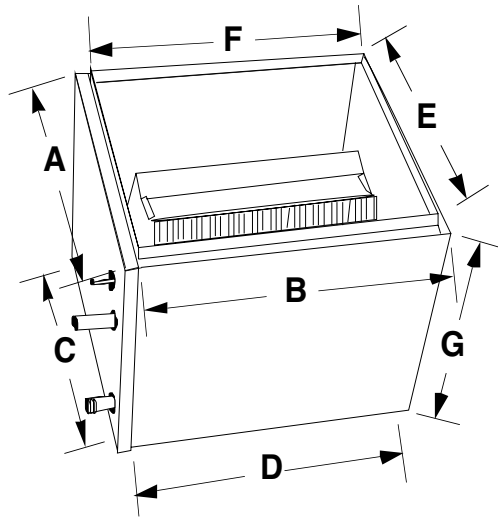

#### GENERAL SPECIFICATIONS

- Standard refrigerant connections: liquid line - 3/8" ODS, suction line - 7/8" ODS
- Right-hand refrigerant and plumbing connections.
- One 3/4" MPT condensate drain.
- Powder-painted metal drain pan. Stainless available.
- Five-year warranty.
- Flowrater standard. Factory or field-installable TXV available.
- Front access panel for easy service.
- Every coil immersion-tested at 500 psi, then nitrogen-pressurized and sealed.
- Heavy gauge embossed galvanized cabinets fully lined with 1/2" faced insulation.
- Flush-fits furnace in most applications.
- Rifled copper tubing, enhanced aluminum fins.
- ARI certifiable with all brands of A/C and heat pump systems.
- ETL listed.

FURNACE MODEL	COIL MODEL	SUFFIX	FOOTPRINT		BOTTOM OPENING		TOP OPENING		HEIGHT
			A	B	C	D	E	F	
N8MP*050B12	BVR** 24	C4M12	15-3/4	21	14-1/4	18-3/4	14-3/4	15-1/4	12
N8MP*075B12	BV1** 24	C4M18	15-3/4	21	14-1/4	18-3/4	14-3/4	15-1/4	18
	BVR** 30	C4M18	15-3/4	21	14-1/4	18-3/4	14-3/4	15-1/4	18
N9MP*050B12A	BV1** 30	C4M18	15-3/4	21	14-1/4	18-3/4	14-3/4	15-1/4	18
N9MP*075B12A	BVR** 36	C4M18	15-3/4	21	14-1/4	18-3/4	14-3/4	15-1/4	18
	BV5** 36	C4M18	15-3/4	21	14-1/4	18-3/4	14-3/4	15-1/4	18
N8MP*075F16	BVR** 36	C4N18	19-1/8	21	17-7/8	18-3/4	17-3/8	15-1/4	18
N8MP*100F14	BV5** 36	C4N18	19-1/8	21	17-7/8	18-3/4	17-3/8	15-1/4	18
N8MP*100F20	BVR** 42	C4N18	19-1/8	21	17-7/8	18-3/4	17-3/8	15-1/4	18
N9MP*050F12A	BV5** 42	C4N24	19-1/8	21	17-7/8	18-3/4	17-3/8	15-1/4	24
N9MP*075F12A	BVR** 48	C4N24	19-1/8	21	17-7/8	18-3/4	17-3/8	15-1/4	24
N9MP*080F16A	BV1** 48	C4N24	19-1/8	21	17-7/8	18-3/4	17-3/8	15-1/4	24
N9MP*100F14A	BV5** 48	C4N24	19-1/8	21	17-7/8	18-3/4	17-3/8	15-1/4	24
N8MP*100J22	BVR** 48	C4P20	22-3/4	21	21-1/2	18-3/4	21	15-1/4	20
N8MP*125J20	BV1** 48	C4P26	22-3/4	21	21-1/2	18-3/4	21	15-1/4	26
N8MP*125J22	BV5** 48	C4P26	22-3/4	21	21-1/2	18-3/4	21	15-1/4	26
	BV1** 60	C4P26	22-3/4	21	21-1/2	18-3/4	21	15-1/4	26
N9MP*100J20A	BV2** 60	CHA26	22-3/4	23	21-1/2	18-3/4	21	15-1/4	26
N9MP*125J20A	BV7** 60	C4P26	22-3/4	21	21-1/2	18-3/4	21	15-1/4	26
	BV1** 60	C5T26	24-1/2	21	21-1/2	18-3/4	23-1/4	15-1/4	26
N9MP*125L20A	BV2** 60	C5W26	24-1/2	23	21-1/2	18-3/4	23-1/4	15-1/4	26
	BV7** 60	C5T26	24-1/2	21	21-1/2	18-3/4	23-1/4	15-1/4	26