



ASPEN
MANUFACTURING

373 ATASCOCITA RD. • HUMBLE, TX • 77396
TEL (281) 441-6500 • FAX (281) 441-6510
<< www.aspenmfg.com >>

DIMENSIONS AND SPECIFICATIONS

Aspen Cased Upflow/Downflow Coils

Designed for Rheem or Ruud Furnaces

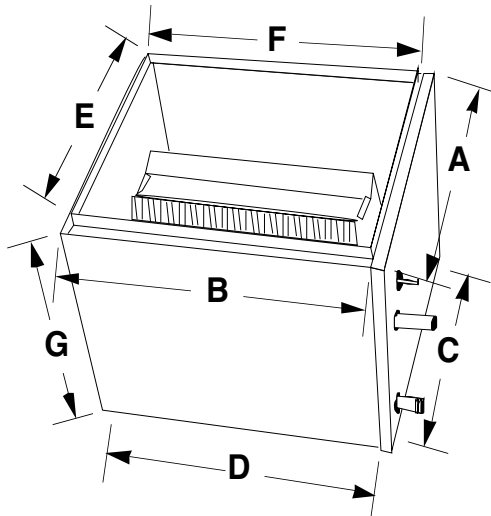

GENERAL SPECIFICATIONS

- Standard refrigerant connections: liquid line - 3/8" ODS, suction line - 7/8" ODS
- Left-hand refrigerant and plumbing connections.
- One 3/4" MPT condensate drain.
- Powder-painted metal drain pan. Stainless available.
- Five-year warranty.
- Flowrater standard. Factory or field-installable TXV available.
- Front access panel for easy service.
- Every coil immersion-tested at 500 psi, then nitrogen-pressurized and sealed.
- Heavy gauge embossed galvanized cabinets fully lined with 1/2" faced insulation.
- Flush-fits furnace in most applications.
- Rifled copper tubing, enhanced aluminum fins.
- ARI certifiable with all brands of A/C and heat pump systems.
- ETL listed.

RHEEM / RUUD FURNACE MODEL	COIL MODEL	SUFFIX	FOOTPRINT		BOTTOM OPENING		TOP OPENING		HEIGHT
			A	B	C	D	E	F	
R/UGDG-, R/UJLG-, R/UGVH-05	BV1** 24	CKD14	14	21-3/4	13	20-1/4	12-7/8	19-3/4	14
	BV1** 30	CKD14	14	21-3/4	13	20-1/4	12-7/8	19-3/4	14
	BV1** 36	CKD20	14	21-3/4	13	20-1/4	12-7/8	19-3/4	20
	BV5** 36	CKD20	14	21-3/4	13	20-1/4	12-7/8	19-3/4	20
R/UGDG-, R/UJLG-, R/UGVH-07, 10(-)A	BV1** 36	CKY24	17-1/2	21-3/4	16-1/2	20-1/4	16-3/8	19-3/4	24
	BV5** 36	CKY18	17-1/2	21-3/4	16-1/2	20-1/4	16-3/8	19-3/4	18
	BV1** 42	CKY24	17-1/2	21-3/4	16-1/2	20-1/4	16-3/8	19-3/4	24
	BV5** 42	CKY24	17-1/2	21-3/4	16-1/2	20-1/4	16-3/8	19-3/4	24
	BV1** 48	CKY24	17-1/2	21-3/4	16-1/2	20-1/4	16-3/8	19-3/4	24
	BV5** 48	CKY24	17-1/2	21-3/4	16-1/2	20-1/4	16-3/8	19-3/4	24
R/UGDG-, R/UJLG-, R/UGVH-10(-)B	BV1** 48	CKX26	21	21-3/4	20	20-1/4	19-7/8	19-3/4	26
	BV5** 48	CKX26	21	21-3/4	20	20-1/4	19-7/8	19-3/4	26
	BV7** 60	CKX26	21	21-3/4	20	20-1/4	19-7/8	19-3/4	26
	BV2** 60	CKJ26	21	23	20	20-1/4	19-7/8	19-3/4	26
R/UGDG-, R/UJLG-, R/UGVH-12, 15	BV1** 48	CKZ26	24-1/2	21-3/4	23-1/2	20-1/4	23-3/8	19-3/4	26
	BV5** 48	CKZ26	24-1/2	21-3/4	23-1/2	20-1/4	23-3/8	19-3/4	26
	BV7** 60	CKZ26	24-1/2	21-3/4	23-1/2	20-1/4	23-3/8	19-3/4	26
	BV2** 60	CKL26	24-1/2	23	23-1/2	20-1/4	23-3/8	19-3/4	26

NOTE: Please specify on order if coil is to be used with both 80+ and 90+ furnaces. Refrigerant and plumbing connections will be centered 7" from left side of coil cabinet.