

A2L RDS KITS

Field
Mounting
Instructions

INSTALLATION GUIDE & FIELD MOUNTING INSTRUCTIONS

ASPEN A2L MITIGATION
CONTROL SYSTEM



OVERVIEW: The mitigation control system consists of a refrigerant detection sensor mounted on a sensor bracket, wire harness connecting the sensor to the mitigation board, a control box with a mitigation control board and optional relay, and a wire harness for connecting the system to a new/ existing field wiring/air moving system.

Refer to Figure-A and A1 below for complete system:

Figure A - Mitigation Control System

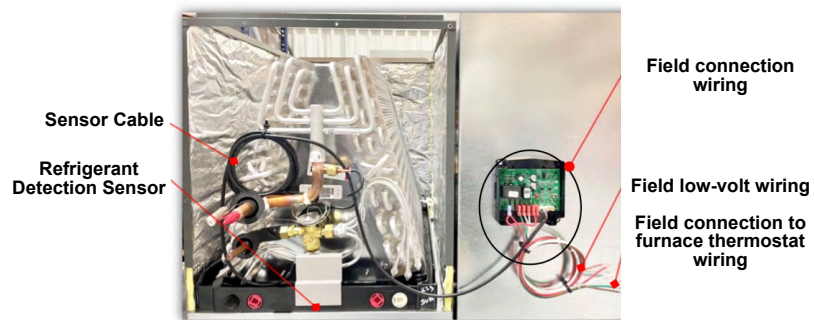
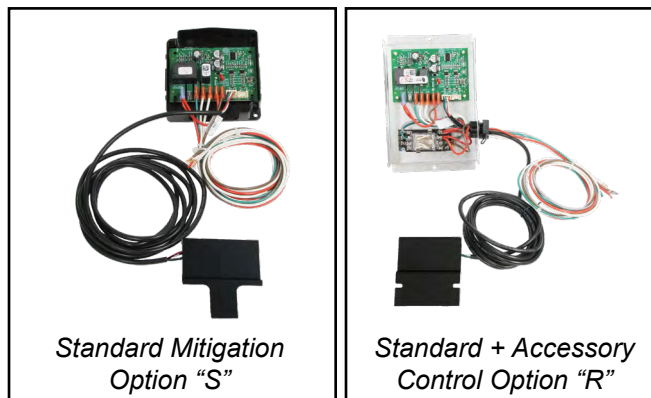

Figure A1 - Mitigation Control Boards
(cover removed to show internal components)



INSTALLATION: The mitigation system is required to be installed in the field by an A2L-trained HVAC contractor at the time of installation following these steps:

1. For cased A-coils, remove coil casing front panels to expose the entire evaporator coil. For uncased coils, slide the coil into the field provided coil casing. For slab coils, remove the side panel on the refrigerant piping side. For dedicated horizontal/plenum coils, skip to step three.



373 Atascocita Rd.,
Humble, TX 77396
Phone: 800.423.9007
Fax: 281.441.6510
www.aspenmfg.com

2. Slide the red discs (one for the liquid and suction line each) over the field piping and away from the brazing area. Follow the instruction guidelines outlined in the coil's installation manual for brazing and installing the evaporator coil.

3. Attach sensor bracket, ensuring it is in the vertical position, on the drain pan as shown in Figure-B below. For specific sensor bracket locations, please refer to Tables 12.2A and B in the IOM:

Figure B

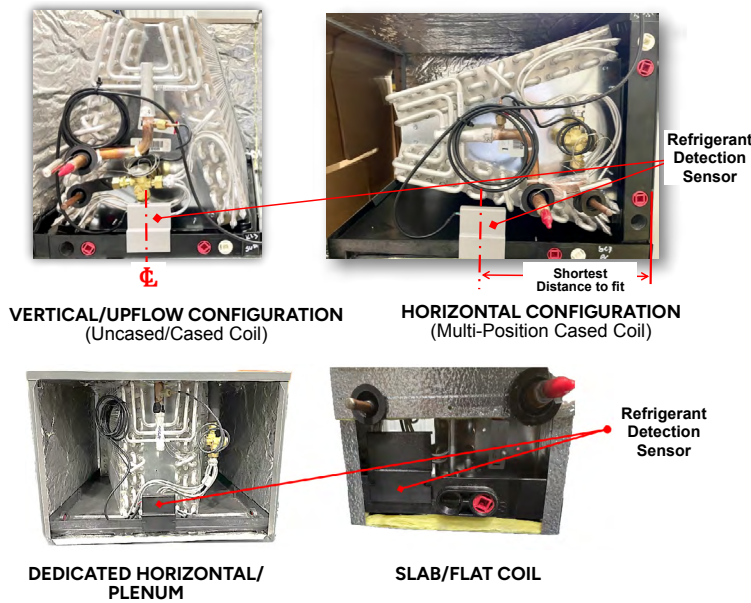

4. Run sensor cable through an opening in the casing. Use grommet supplied in the kit for hole (0.875") in the sheet metal to ensure cable is not damaged when exiting the coil casing. The installing contractor must ensure there is a drip loop created (shown in Figure-C below) in the harness to ensure condensation does not run into the sensor connection.

Figure C

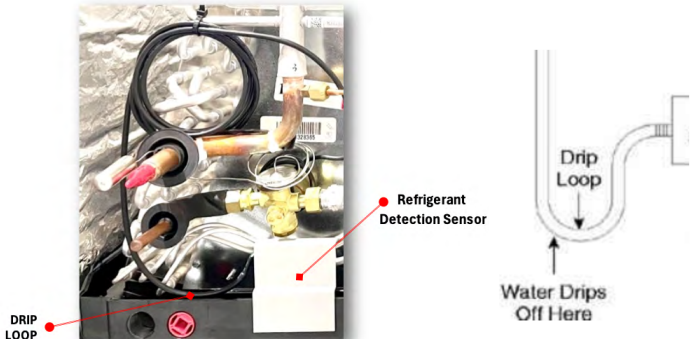

5. Mount mitigation board enclosure to a nearby flat, vertical surface by using a.) the included two-sided tape or b.) using field-supplied screws; see Figure-D below for more details. The enclosure must be mounted perpendicularly flush to a wall or permanent structure near the coil within three (3) feet of the furnace. Do NOT mount the enclosure to the outside of the furnace or evaporator coil casing as damage could occur to the equipment. Keep the enclosure clear of the furnace flue pipes.

Figure D

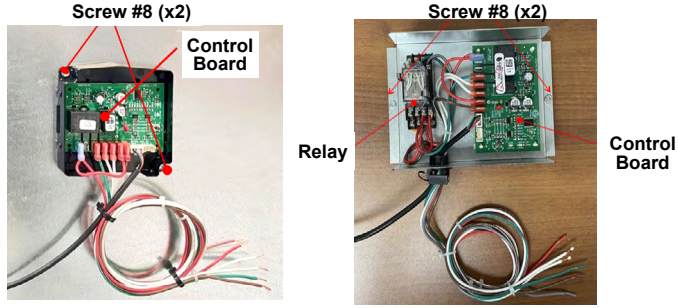

6. Connect the sensor cable to the control board in the enclosure. Connect the low-voltage wires into the existing/new wiring / air moving system as in Figure-E below:

Figure E

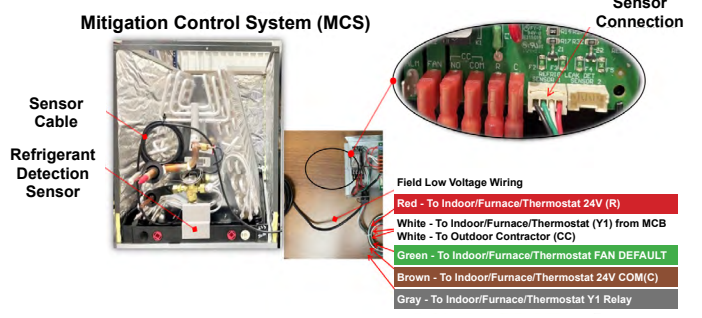

7. For uncased coils, apply warning labels included in the kit to the coil casing, ensuring they are visible from the front of the coil. For cased A-coils, dedicated /plenum, and slab coils, the labels will be applied to the casing at the factory.

Close the casing holding the evaporator coil. Slide the discs so they reside just outside of the coil cabinet. For dedicated horizontal/plenum coils, apply disc to refrigerant lines prior to brazing field piping. See Figure-F below for pictorial representation. These markings will alert any technician servicing the installation in the future that the system is charged with an A2L refrigerant.

Figure F



VERIFICATION: RUNNING THE SYSTEM TEST IS MANDATORY FOR ALL INSTALLATIONS. THE HVAC SYSTEM MUST NOT COMPLETE COMMISSIONING UNTIL THE INSTALLATION STEPS OUTLINED IN THIS MANUAL HAVE BEEN SUCCESSFULLY COMPLETED.

IMPORTANT: Never connect sensor to the mitigation control board while board is powered; ensure system is powered off prior to working on this mitigation system. Use only the “SENSOR1” PORT; the “SENSOR2” port shall only be used in applications with two indoor units in which the sensor will also connect to the mitigation control board. If the sensor is not connected prior to powering up the mitigation system, it will enter leak mitigation mode. Once the system enters leak mitigation mode, it will stay in mitigation state for at least five (5) minutes, even if the control board loses power or the power is cycled. Therefore, it is strongly advised to connect the sensor prior to powering up.

Perform the A2L Mitigation Control refrigerant leakage test for all modes of operation one by one – Cooling (for ACs & heat pumps), Heating (for heat pumps), Electric Heating, and Fan modes.

Applications with Standard A2L Mitigation Kit (Option “S”):

Set the thermostat to one of the above operation modes, and ensure that the system is powered and running properly in that mode. The test sequence will need to be performed again in each operation mode. Open the enclosure to access the mitigation control board. Once the system is powered, the control will communicate with the A2L sensor to request data on the concentration of airborne refrigerant within the coil cabinet, wait 10 seconds, and verify that the STATUS LED shows Warm-Up mode (solid ON), then wait 20 – 30 seconds and verify that the STATUS LED shows Run mode (solid OFF).

1. Locate the sensor cable connected to the “SENSOR1” port on the mitigation control board. Remove the sensor cable by squeezing the tab on the connector and pulling away from the board to disconnect the sensor.

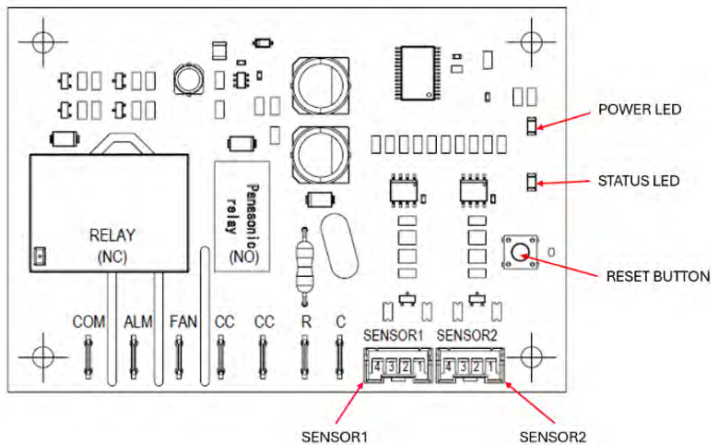

NOTE: The A2L Mitigation Control for Aspen’s applications are set up on Auto Reset so the manual function RESET BUTTON is disabled.

2. Once the sensor is disconnected, wait 15 seconds, the mitigation control board no longer detects the sensor, verify that the STATUS LED blinks fault code for communication fault (2 blinks), the mitigation sequence begins:

- i. The HVAC system operation that was chosen the control will provide a system response which will deactivate the compressor and energize the indoor blower.
 - ii. The indoor blower will begin to operate and remain running for at least 5 minutes from initial fault detection. The STATUS LED (2 blink) fault code will continue for the entire 5 minutes.
 - iii. Once steps b. i., and b. ii. have been confirmed the test is considered successful. It is recommended to wait the entire 5 minutes to allow the test sequence to expire.
3. Cycle the system power off, reconnect the sensor to the “SENSOR1” port, then power up the system to verify that the STATUS LED shows Warm-Up mode (solid ON). Wait 20-30s, then verify that the STATUS LED shows Run mode (solid OFF). For systems that only require one sensor, the test is complete.

NOTE: If the A2L REFRIGERANT DETECTION SYSTEM IS NOT FUNCTIONING PROPERLY FOR ANY OF THE OPERATION MODES, RE-CHECK THE WIRING DIAGRAM FOR YOUR INSTALLED SYSTEM AND DO NOT CONTINUE UNTIL THE ISSUE HAS BEEN RESOLVED.

WIRING DIAGRAMS - STANDARD: SINGLE STAGE AIR CONDITIONER

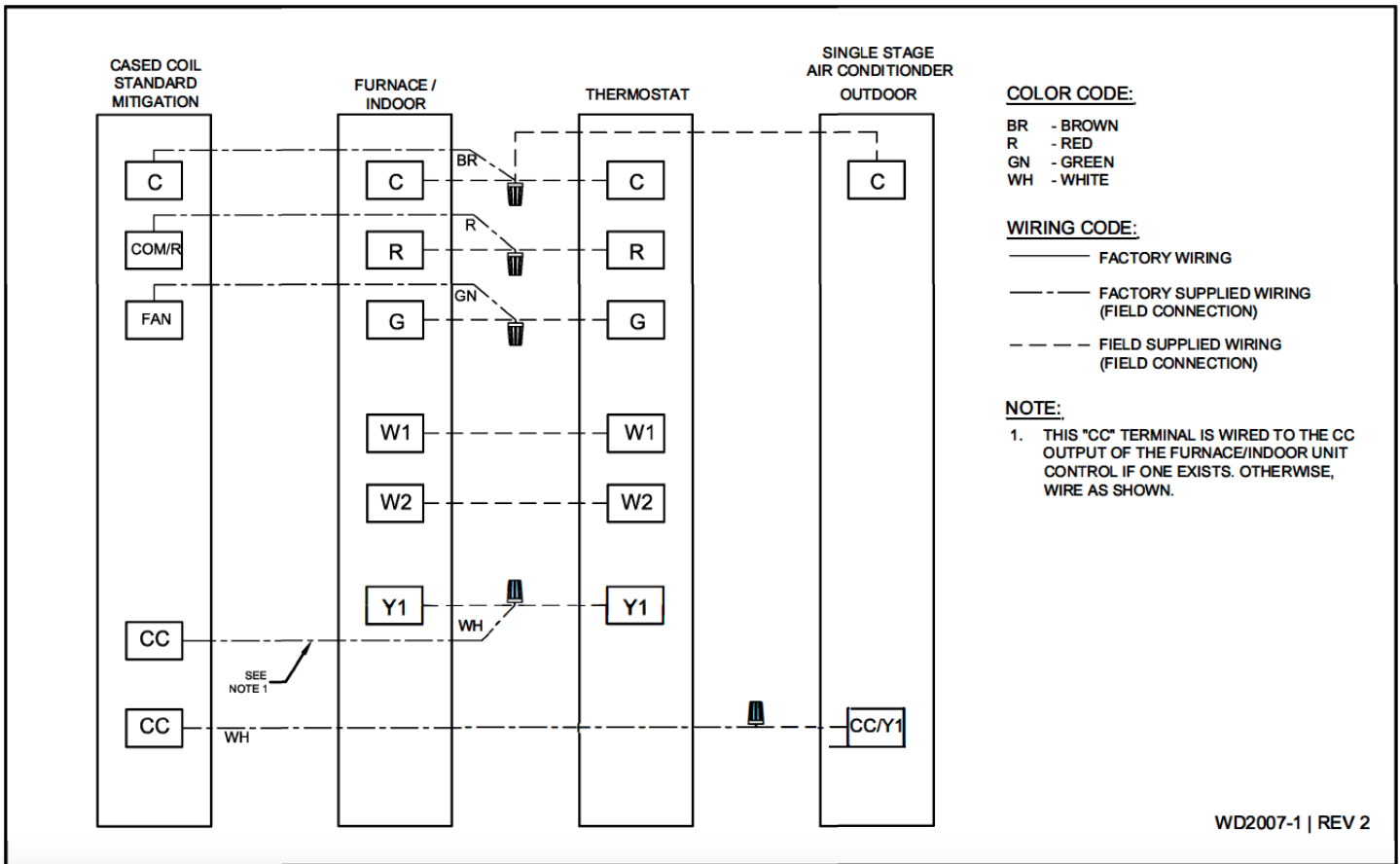

2 STAGE AIR CONDITIONER

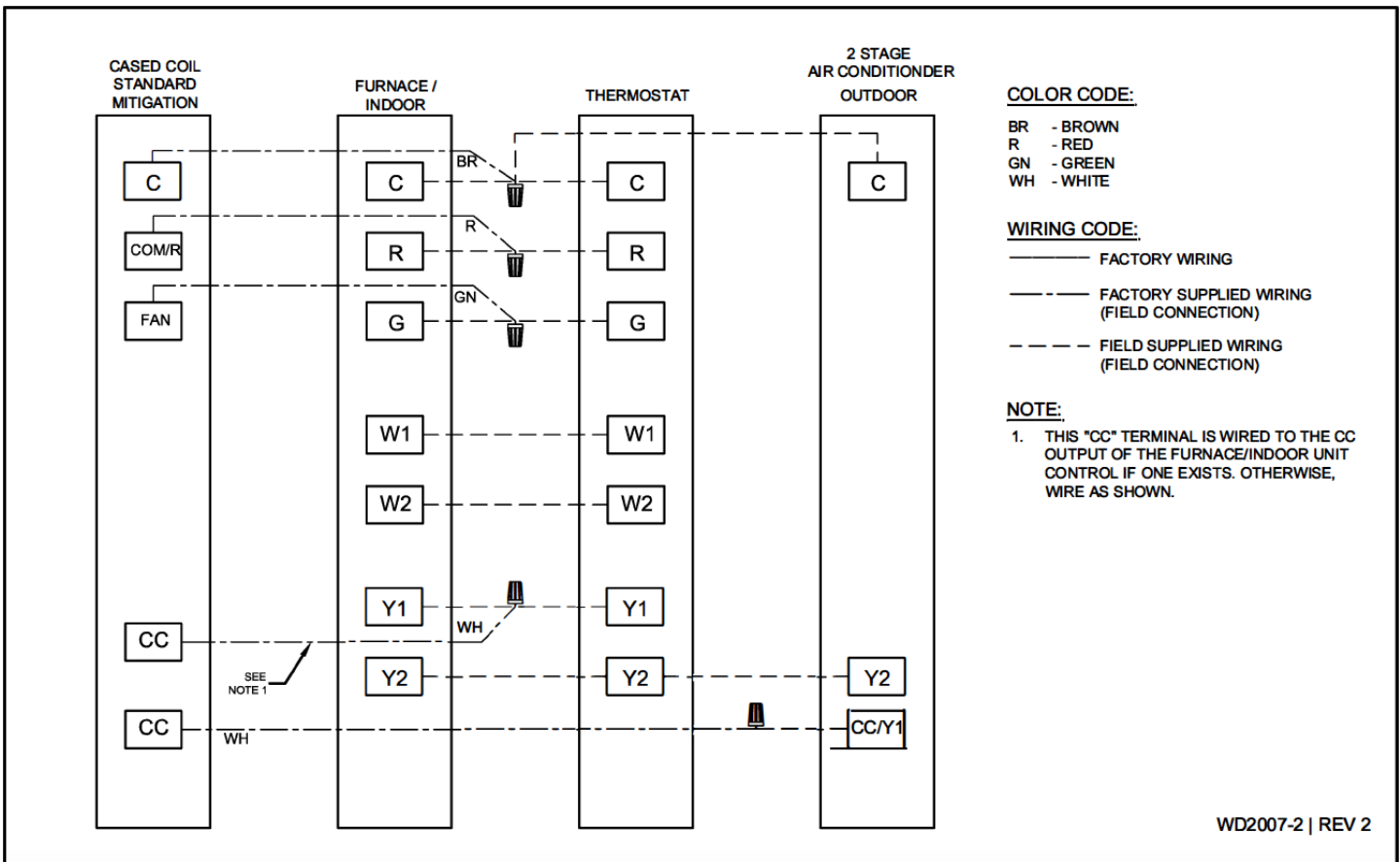

SINGLE STAGE HEAT PUMP

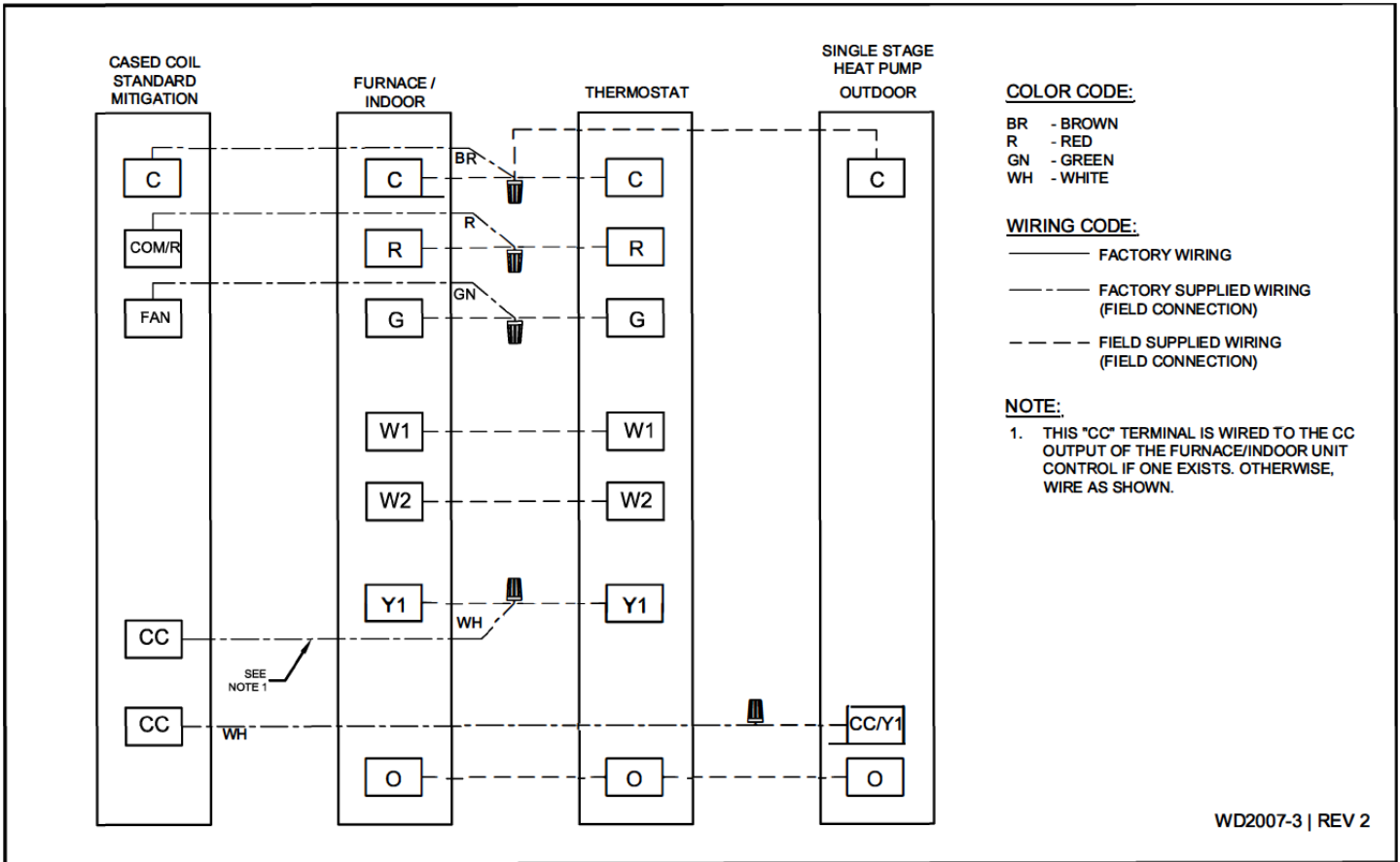

2 STAGE HEAT PUMP

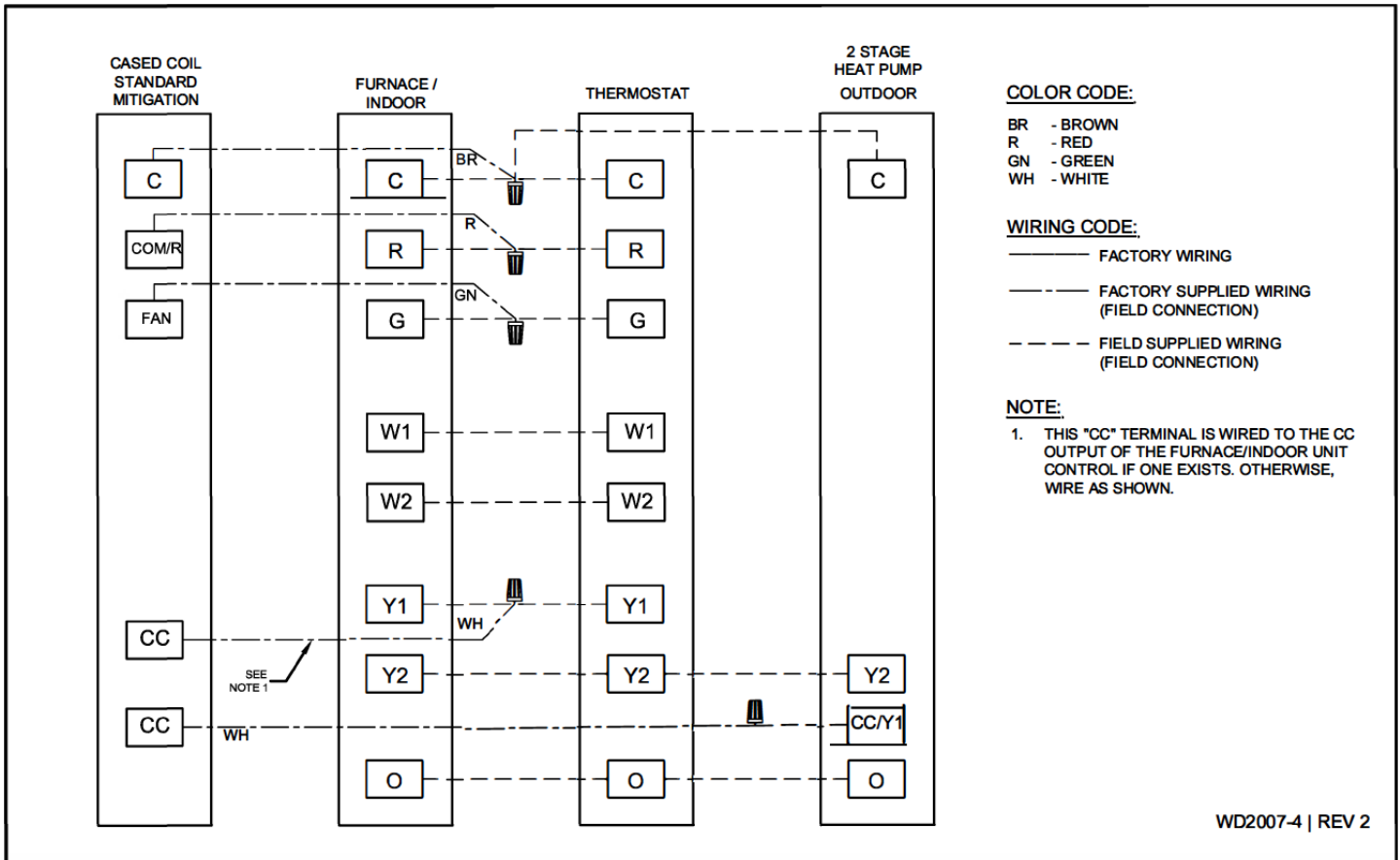

Applications with Standard A2L Mitigation Kit (Option “S”):

The “Accessory Control Kit” includes a relay and a wire harness used to de-energize the W1 & W2 call or to energize or de-energize add on equipment / accessories or functions.

Set the thermostat to one of the above operation modes, and ensure that the system is powered and running properly in that mode. The test sequence will need to be performed again in each operation mode. Open the enclosure by removing the two screws and the metal cover to access the mitigation control board and accessory control relay. Once the system is powered, the control will communicate with the A2L sensor to request data on the concentration of airborne refrigerant within the coil cabinet, wait 10 seconds, and verify that the STATUS LED shows Warm-Up mode (solid ON), then wait 20 – 30 seconds and verify that the STATUS LED shows Run mode (solid OFF).

1. Locate the sensor cable connected to the “SENSOR1” port on the mitigation control board. Remove the sensor cable by squeezing the tab on the connector and pulling away from the board to disconnect the sensor.

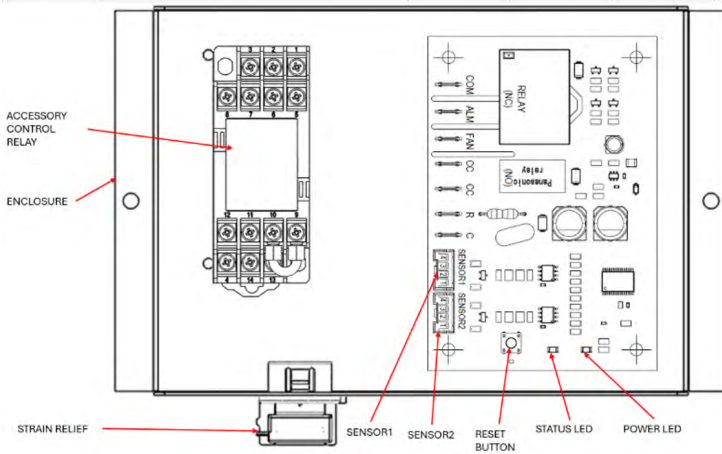

2. Once the sensor is disconnected, wait 15 seconds, the mitigation control board no longer detects the sensor, verify that the STATUS LED blinks fault code for communication fault (2 blinks), the mitigation sequence begins:
 - i. The HVAC system operation that was chosen the control will provide a system response which will deactivate the compressor and the additional equipment/ accessory that is connected to the terminals 3, 4 and 11, 12 of the relay such as but not limited to electric heat or gas heat or air cleaner at the same time, then it will energize the indoor blower. See the relay and wiring diagram below for details.

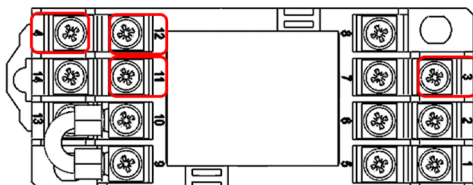

2. Once the sensor is disconnected, wait 15 seconds, the mitigation control board no longer detects the sensor, verify that the STATUS LED blinks fault code for communication fault (2 blinks), the mitigation sequence begins:
 - i. The HVAC system operation that was chosen the control will provide a system response which will deactivate the compressor and the additional equipment/ accessory that is connected to the terminals 3, 4 and 11, 12 of the relay such as but not limited to electric heat or gas heat or air cleaner at the same time, then it will energize the indoor blower. See the relay and wiring diagram below for details.
 - ii. The indoor blower will begin to operate and remain running for at least 5 minutes from initial fault detection. The STATUS LED (2 blink) fault code will continue for the entire 5 minutes.
 - iii. Once steps b. i., and b. ii. have been confirmed the test is considered successful. It is recommended to wait the entire 5 minutes to allow the test sequence to expire.

NOTE: Loss of communication between the control and the sensor will also result in the mitigation state for at least 5 minutes. The control will not recover until communication is restored.

WIRING DIAGRAMS - WITH ACCESSORY CONTROL KIT:

SINGLE STAGE AIR CONDITIONER

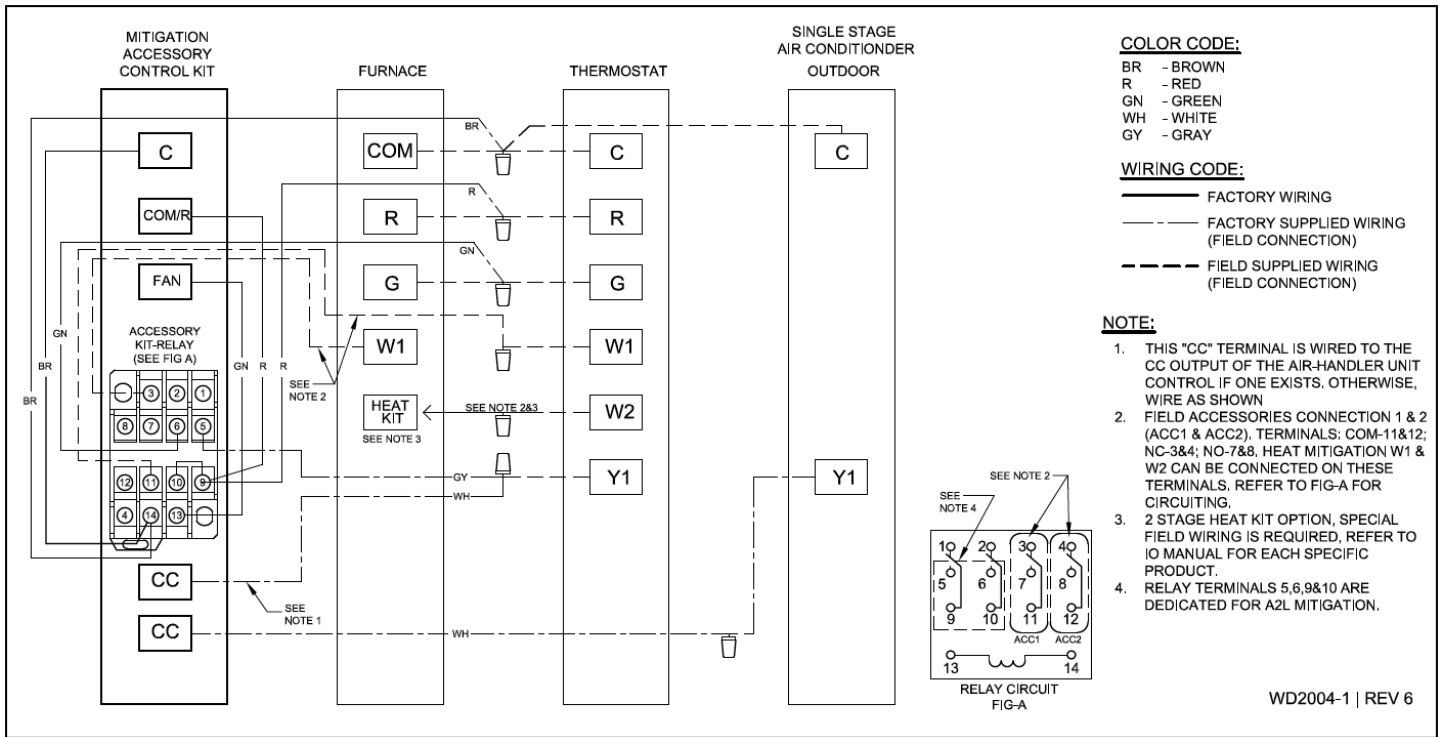

2 STAGE AIR CONDITIONER

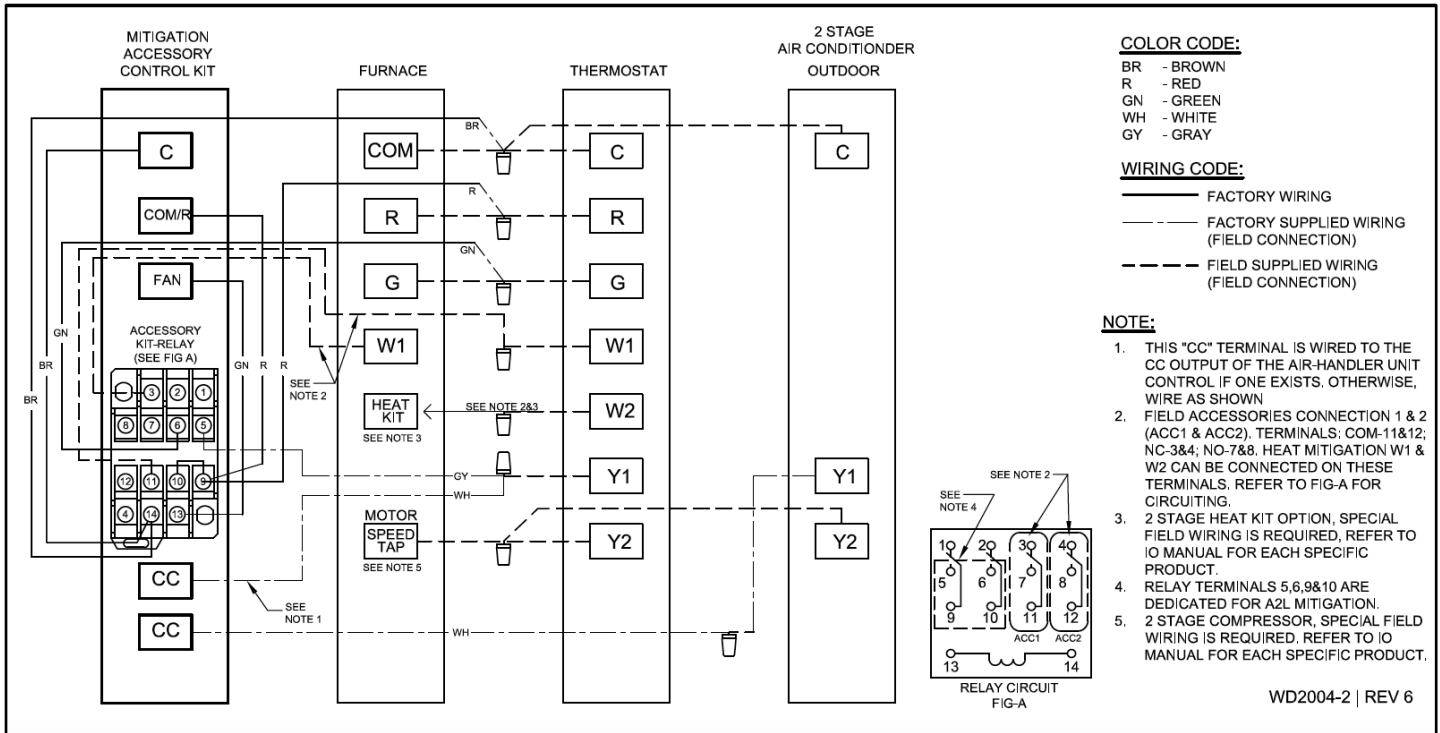

SINGLE STAGE HEAT PUMP

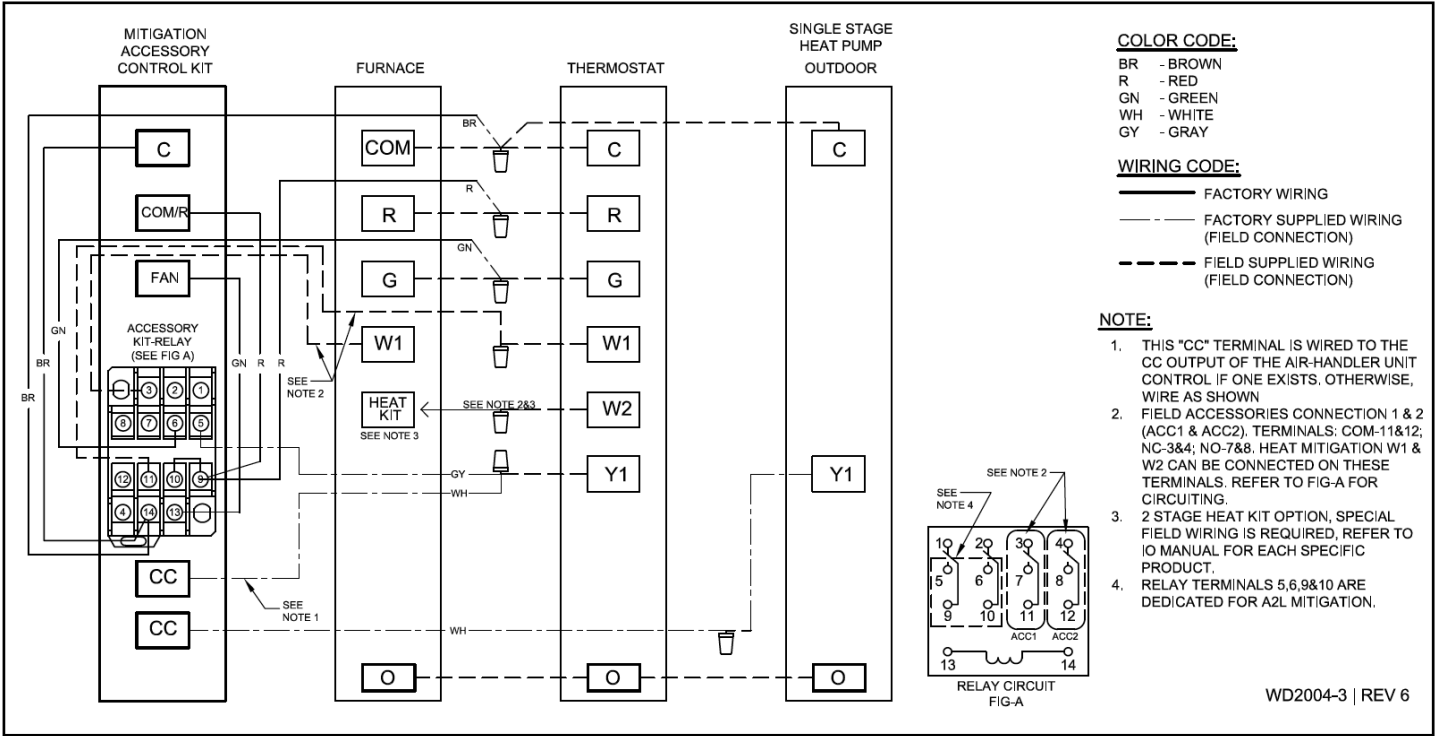

2 STAGE HEAT PUMP

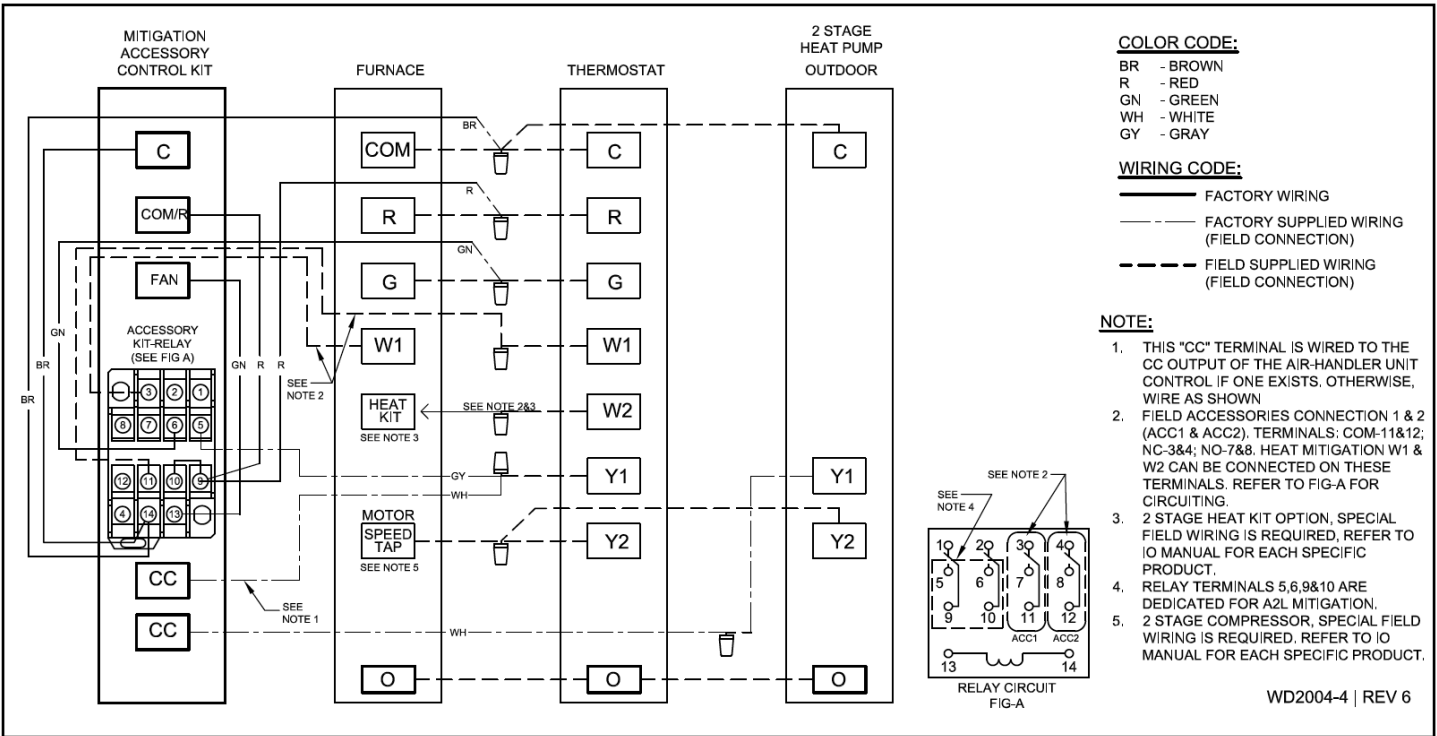



Scan QR Code to visit
Aspen's A2L RDS Kit
Spec Sheet



373 Atascocita Rd.
Humble, TX 77396
Phone: 281.441.6500
Toll Free: 800.423.9007
Fax: 281.441.6510
www.aspenmfg.com



Scan QR Code to visit
Aspen's website

Revised 02/2025. Subject to change without notice and without incurring obligation.

© Copyright 2025 Aspen Manufacturing. All Rights Reserved